

HB

中华人民共和国航空工业部部标准

HB3901-86

普通螺纹校对塞规

M52×1~M100×2 校通-止TZ 校通-损TS

1986-12-30发布

1987-10-01实施

中华人民共和国航空工业部 批准

普通螺纹校对塞规
 校通—止 TZ 校通—退 TS
 M52×1~M100×2

代替

其余 $\nabla 3.2$

M52×1

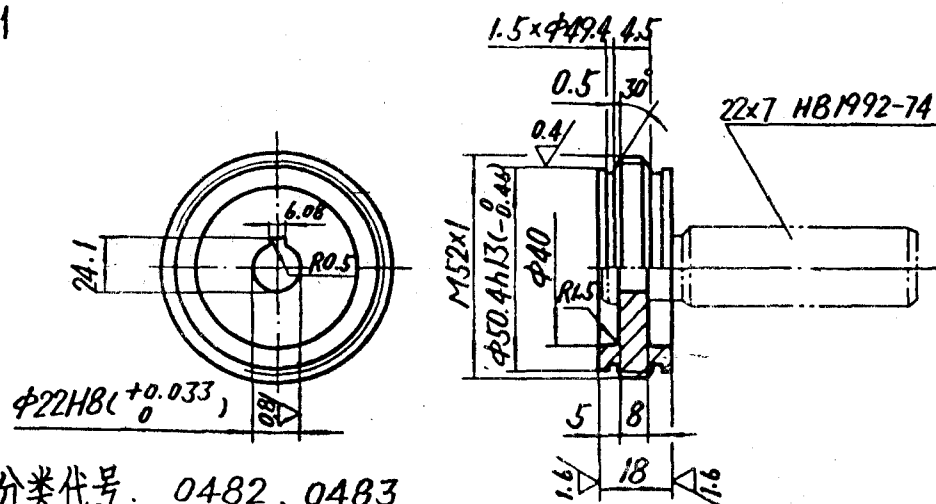

分类代号: 0482, 0483

标记示例: M52×1-3h4h TZ 的螺纹校对塞规 0482 / M52×1-3h-TZ
 0483 / M52×1-3h-TS

| 螺纹 公差带 | TZ | | | | | TS | | | | |
|--------------|---------|---------|---------|---------|---------|---------|---------|---------|---------|---------|
| | 大 径 | | 中 径 | | 小 径 | 大 径 | | 中 径 | | 小 径 |
| | 基本尺寸 | 极限偏差 | 基本尺寸 | 极限偏差 | ≤ | 基本尺寸 | 极限偏差 | 基本尺寸 | 极限偏差 | ≤ |
| 3h4h | 51.557 | ±0.0035 | 51.357 | ±0.0035 | 50.912 | 51.564 | ±0.0035 | 51.364 | ±0.0035 | 50.912 |
| 4h 5h4h 5h6h | 51.555 | ±0.0045 | 51.355 | ±0.004 | 50.910 | 51.564 | ±0.0045 | 51.364 | ±0.004 | 50.910 |
| 6h 7h6h | 51.551 | ±0.0055 | 51.351 | ±0.0045 | 50.908 | 51.563 | ±0.0055 | 51.363 | ±0.0045 | 50.908 |
| 8h | 51.5495 | ±0.007 | 51.3495 | ±0.006 | 50.9055 | 51.5635 | ±0.007 | 51.3635 | ±0.006 | 50.9055 |
| 5g6g | 51.529 | ±0.0045 | 51.329 | ±0.004 | 50.884 | 51.538 | ±0.0045 | 51.338 | ±0.004 | 50.884 |
| 6g 7g6g | 51.525 | ±0.0055 | 51.325 | ±0.0045 | 50.882 | 51.537 | ±0.0055 | 51.337 | ±0.0045 | 50.882 |
| 8h | 51.5235 | ±0.007 | 51.3235 | ±0.006 | 50.8795 | 51.5375 | ±0.007 | 51.3375 | ±0.006 | 50.8795 |
| 6f | 51.511 | ±0.0055 | 51.311 | ±0.0045 | 50.868 | 51.523 | ±0.0055 | 51.323 | ±0.0045 | 50.868 |
| 6e | 51.491 | ±0.0055 | 51.291 | ±0.0045 | 50.848 | 51.503 | ±0.0055 | 51.303 | ±0.0045 | 50.848 |

1. 材料: CrMn 钢, 按 GB1299-77; 或 T12A 钢, 按 GB1298-77。
2. 热处理: 淬火 HRC58~65。
3. 切去两端不完整螺纹。
4. 技术条件按 HB3908-86

普通螺纹校对塞规
校通—止 TZ 校通—损 TS

M56x1

其余 $\nabla 3.2$

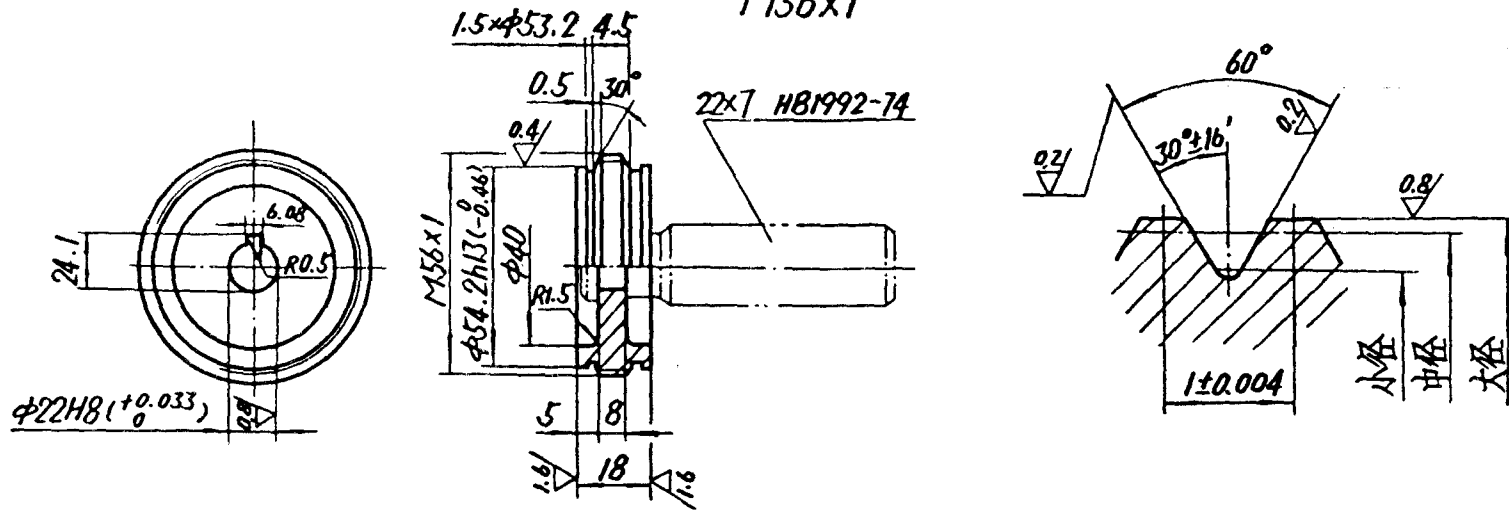

分类代号: 0482, 0483

标记示例: M56x1-3h4h $\frac{TZ}{TS}$ 的螺纹校对塞规 0482 / M56x1-3h-TZ
0483 / M56x1-3h-TS

| 螺纹 公差带 | TZ | | | | | TS | | | | |
|--------------|---------|---------|---------|---------|----------|---------|---------|---------|---------|----------|
| | 大 径 | | 中 径 | | 小 径 ≤ | 大 径 | | 中 径 | | 小 径 ≤ |
| | 基本尺寸 | 极限偏差 | 基本尺寸 | 极限偏差 | | 基本尺寸 | 极限偏差 | 基本尺寸 | 极限偏差 | |
| 3h4h | 55.557 | ±0.0035 | 55.357 | ±0.0035 | 54.912 | 55.564 | ±0.0035 | 55.364 | ±0.0035 | 54.912 |
| 4h 5h4h 5h6h | 55.555 | ±0.0045 | 55.355 | ±0.004 | 54.910 | 55.564 | ±0.0045 | 55.364 | ±0.004 | 54.910 |
| 6h 7h6h | 55.551 | ±0.0055 | 55.351 | ±0.0045 | 54.908 | 55.563 | ±0.0055 | 55.363 | ±0.0045 | 54.908 |
| 8h | 55.5495 | ±0.007 | 55.3495 | ±0.006 | 54.9055 | 55.5635 | ±0.007 | 55.3635 | ±0.006 | 54.9055 |
| 5g6g | 55.529 | ±0.0045 | 55.329 | ±0.004 | 54.884 | 55.538 | ±0.0045 | 55.338 | ±0.004 | 54.884 |
| 6g 7g6g | 55.525 | ±0.0055 | 55.325 | ±0.0045 | 54.882 | 55.537 | ±0.0055 | 55.337 | ±0.0045 | 54.882 |
| 8g | 55.5235 | ±0.007 | 55.3235 | ±0.006 | 54.8795 | 55.5375 | ±0.007 | 55.3375 | ±0.006 | 54.8795 |
| 6f | 55.511 | ±0.0055 | 55.311 | ±0.0045 | 54.868 | 55.523 | ±0.0055 | 55.323 | ±0.0045 | 54.868 |
| 6e | 55.491 | | 55.291 | | 54.848 | 55.503 | | 55.303 | | 54.848 |

1. 材料: CrMn 钢, 按 GB1299-77; 或 T12A 钢, 按 GB1298-77.
2. 热处理: 淬火 HRC 58~65.
3. 切去两端不完整螺纹.
4. 技术条件按 HB3908-86